

Ohm's law and electrical resistance

Resistance is defined to be the ratio of voltage dropped (or *potential difference*) to current flow through an electrical component. For many passive components this will be a constant, i.e. the graph of voltage against current will be linear, with resistance being the gradient. Such components are called *Ohmic*.

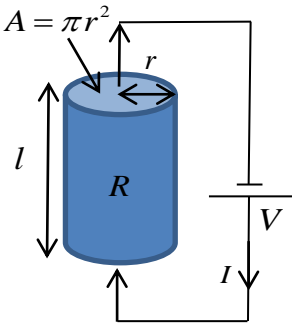

A cylindrical passive resistor of cross-section A and length l will have resistance R in terms of these geometrical parameters and the resistivity ρ of the material.

$$R = \frac{\rho l}{A}$$

Resistivity of various materials

Copper $\rho = 1.68 \times 10^{-8} \Omega\text{m}$
 Aluminium $\rho = 2.82 \times 10^{-8} \Omega\text{m}$
 Gold $\rho = 2.44 \times 10^{-8} \Omega\text{m}$
 Iron $\rho = 1.00 \times 10^{-7} \Omega\text{m}$
 Sea water $\rho = 2.00 \times 10^{-1} \Omega\text{m}$
 Glass $\rho = 10^{11} - 10^{15} \Omega\text{m}$
 Hard rubber $\rho = 10^{13} \Omega\text{m}$
 Dry wood $\rho = 10^{14} - 10^{16} \Omega\text{m}$
 Air $\rho = 1.3 - 3.3 \times 10^{16} \Omega\text{m}$

Typical resistivity values/ Ωm

Constantan	49×10^{-3}
Manganin	44×10^{-3}
Nichrome	100×10^{-3}
Tungsten	55×10^{-3}

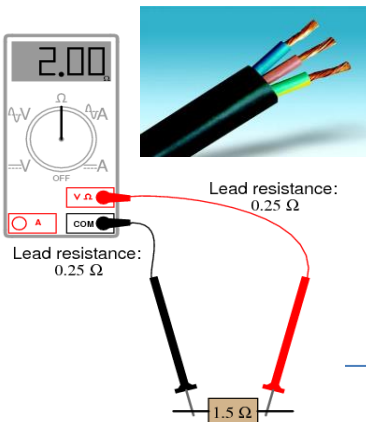

Fixed passive resistor

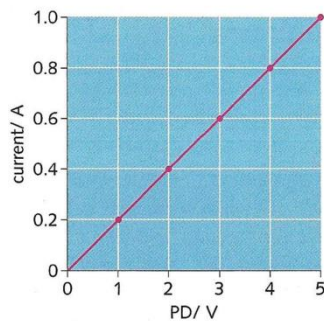

The gradient of this graph is constant since resistance is constant

Filament bulb

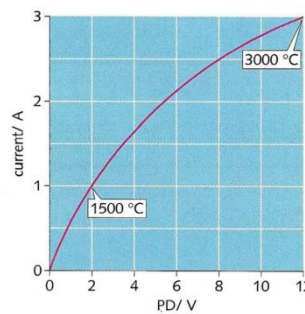

As the more current passes through a bulb it heats up. The increased random motion impedes the free flow of electrons which therefore increases resistance.

Semiconductor diode

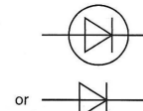
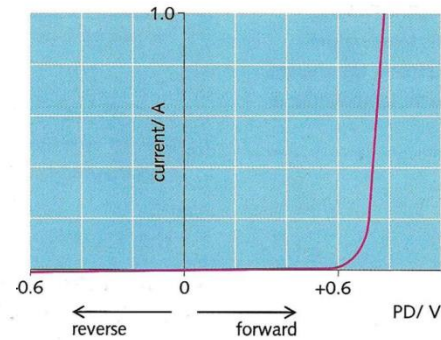

Very little current passes through a diode until a threshold voltage is reached. After this point the diode resistance is very low i.e. a small voltage increase will result in significant increases in current.

Ohm's Law is when $R = \text{constant}$

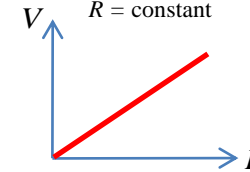

Georg Ohm
1789-1854

Real voltage supplies will have **internal resistance** r . The 'electromotive force' (EMF) (i.e. the actual supply voltage \mathcal{E}) will differ from the actual voltage V across components in a series loop

$$V = \frac{R}{R+r} \mathcal{E}, \quad \mathcal{E} = I(R+r)$$

An **ammeter** is a current measuring device. Since it is placed in series it should have very little resistance so not to result in a significant voltage drop across it.

A **voltmeter** is a voltage measuring device. This is placed in parallel with a component and has a **high internal resistance** to prevent it drawing much current.

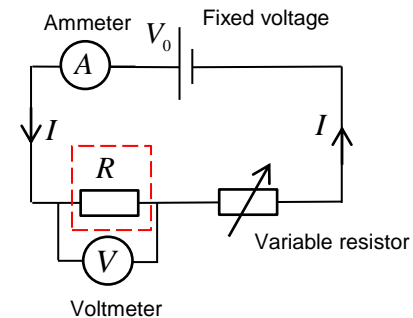

Schematic of experimental setup for measuring the I, V curve of an electrical component. The most efficient way to do this via a *potential divider*. i.e. have a *fixed* supply voltage and then vary the potential across the device by *varying* the resistance of a passive resistor in series. Careful choice of the variable resistance range should be made to result in a significant change in I and V .